

# Application Success Stories

# wanzl

**STORETEC**



**Wanzl have introduced a state-of-the art powder-coating booth to the production line at their Tibshelf manufacturing site in Derbyshire UK.**

Superb coating  
application

Clean operating  
environment

Environmentally  
friendly

# Application Success Stories

## Layout

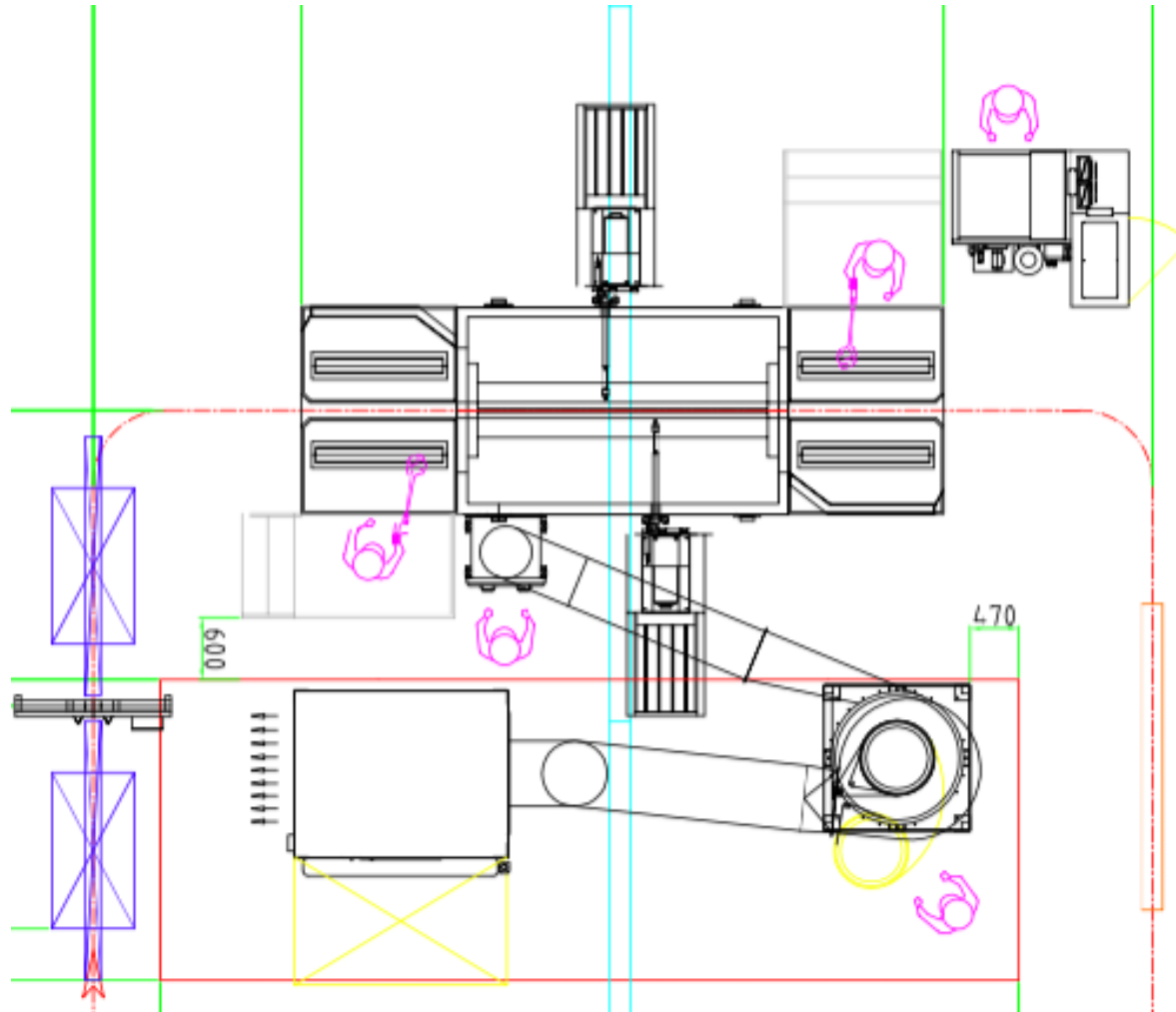

# Application Success Stories

## Installation Key Data

### **Parts:**

Retail shelving, and  
supermarket trolleys

### **Production data:**

- 1800mm high
- 1000mm wide
- 1.5m per min

### **System Type:**

- Magic Compact BA04
- 16.00 m<sup>3</sup>/hr
- 16 Automatic guns
- 2 manual stations
- OptiCenter®
- CM30 control system
- Product recognition
- X & Y reciprocation



# Application Success Stories



**Company Profile:** Wanzl stands for dynamism, reliability and progress. Wanzl retail solutions are always synonymous with exceptional quality, attractive aesthetics and distinctive design combined with optimum ergonomics. As a high-performance and value-oriented family company, as well as a leader when it comes to quality,

our name is our guarantee that we will contribute to the success of our customers with ideas, creativity and service – both now and in the future.

**The investment:** An investment in one of Gema's latest generation powder application booths will deliver significant improvements in efficiency while reducing costs for UK customers who take advantage of Wanzl's unique Reviva remanufacturing process.

# Application Success Stories

## Key objectives and success areas:

- ✓ Reduce applied coating costs
- ✓ Recover and re-use overspray powder
- ✓ Improve the operating environment
- ✓ Reduce waste
- ✓ Improve flexibility
- ✓ Reduce maintenance
- ✓ Increase line density and production output



**Customer feedback:** Operations Director for Wanzl, Tony Barber, explained that the new powder coating booth supplied by Swiss specialists Gema has 'dramatically reduced' colour change times and provides a superior quality finish. At the same time, powder waste has been reduced from 25% to 5%. "Our colour change time is now close to 10 minutes versus about an hour previously which has enormous benefits both in terms of sheer throughput capacity and our ability to flex production to meet shorter runs and fulfill customer needs.

"Over the next few months our many UK customers are visiting Tibshelf to see first-hand the quality, efficiency and cost savings we can achieve for them – whether for wire or flat steel shelving, display

systems or shopping trolleys. Our Reviva brand continues to grow as the smart choice for retailers looking for cost and environmental benefits – and our world-class powder coating service is a now a further value-adding feature of Wanzl's total asset lifecycle model," explained Tony.

He added that Gema powder coating booths are used extensively within the Wanzl manufacturing estate and they welcomed the opportunity to introduce their sophisticated automated systems to Wanzl's Reviva remanufacturing process in the UK.

"We look forward to developing our surface finishing technology with partners such as Gema to the benefit of all our customers in the future," said Tony.