

Application Success Stories

FISCHER GmbH + Co. KG Warehousing engineering business

FISCHER
Lagertechnik + Regalsysteme



Capacity

Quality

Economy

Application Success Stories

Installation Key Data

Parts: Profiles and parts for storage systems

Parts size: H 1'500 mm
W 600 mm
L 12'000 mm

Conveyor speed: v 1,7 m/min

Scope of delivery:

- 1 x MagicCompact® EquiFlow®
- 1 x OptiFlex® Automatic AS06-12P
- 10 x OptiGun® GA03-P-1250 automatic gun
- 2 x OptiSelect® Pro GM04 manual gun
- 1 x OptiCenter® OC08 with 12 x OptiFlow IG07-P
- 1 x MagicControl 4.0 (CM40)
- 2 x ZA07-13 / XT10-10 reciprocator
- 3 x BigBag for fresh powder supply
- 1 x BigBag for waste powder



Application Success Stories

Layout

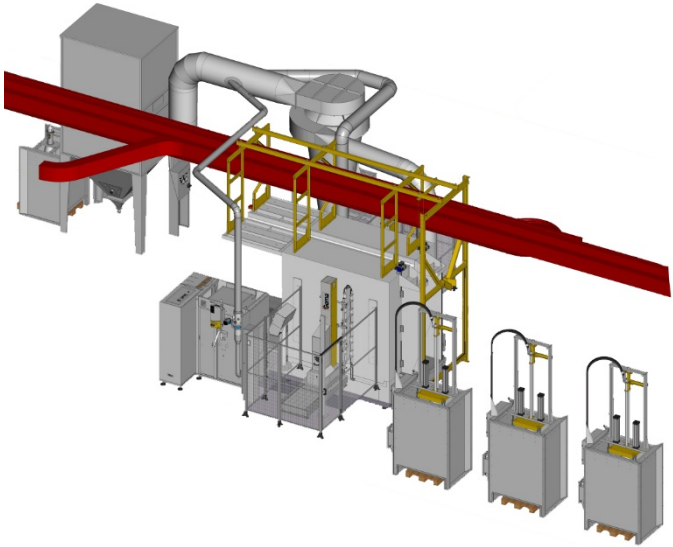
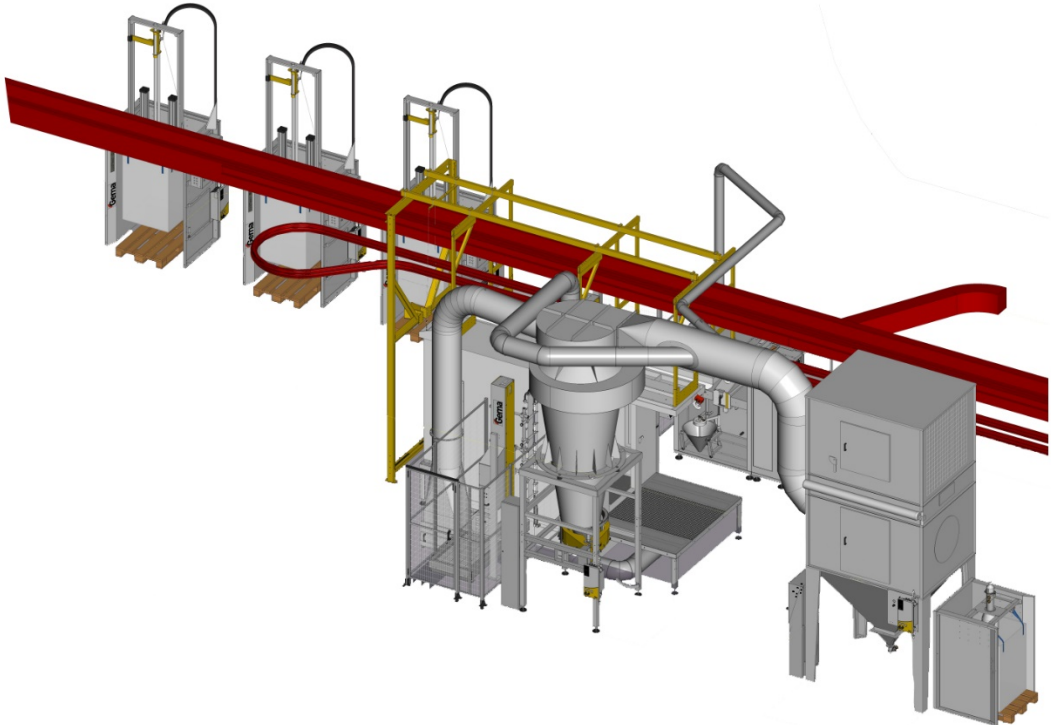

Application Success Stories



Application Success Stories



FISCHER has been active in the field of warehouse and storage technique for more than 40 years and is known throughout Europe for individual warehousing solutions.

Until recently, the profiles and parts for the shelves, platforms and warehouse systems at FISCHER were coated manually. Due to a sharp rise in demand and increasing individualization in shape and color, FISCHER decided to invest in an automated solution. The aim was to double the coating



capacity with the same workforce and to improve the efficiency and process reliability.

After intensive planning of the new complete system, FISCHER chose the EquiFlow quick color change technology by Gema for the application. Fresh powder is continuously fed from three BigBag systems to the OptiCenter OC08 powder center. The parts are coated with 10 automatic guns. At the bright and spacious recoating station, two manual coaters check and correct



critical areas if necessary. All coating processes are controlled centrally via the MagicControl 4.0 control system. The waste powder is collected in a BigBag.

By changing from manual to automatic coating, FISCHER has doubled its capacity, increased profitability and raised the quality standard once again. This has enabled FISCHER to consolidate its competitiveness in a market that increasingly demands fast reaction times and economical solutions.