

Application Success Stories

First Retrofit Manual Line to Achieve Full Automation In The Peer

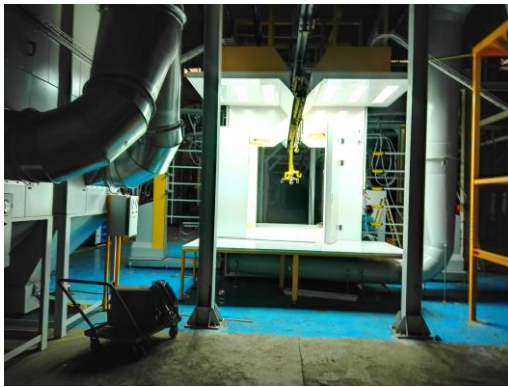

Quality and
Production
Improved



Cost Saving



Environment
Friendly

Application Success Stories

Layout

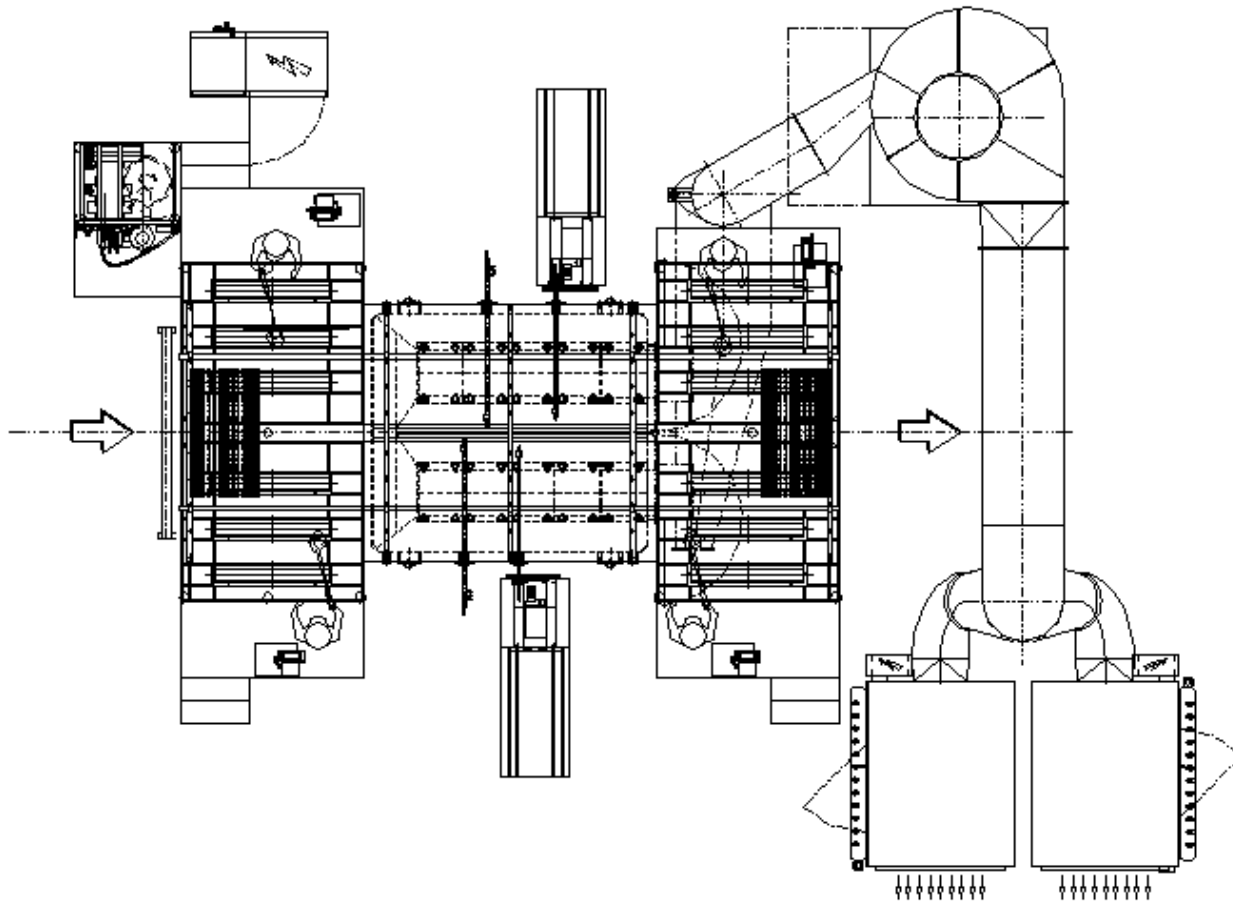

Application Success Stories

Installation Key Data

Parts: *Construction machinery*

Object sizes:

- H 1800 mm

- W 1720 mm

Conveyor Speed: *1.5 m/min*

Scope of delivery:

1x MagicPlus Equiflow booth

1x OptiCenter OC02

1x OptiFlex AS05-14P

14x OptiGun GA03 AX-SC Auto gun

3x Optiselect GM03 manual gun

1x Magic control CM30

2x ZA05/18+XT11

1x Light barrier

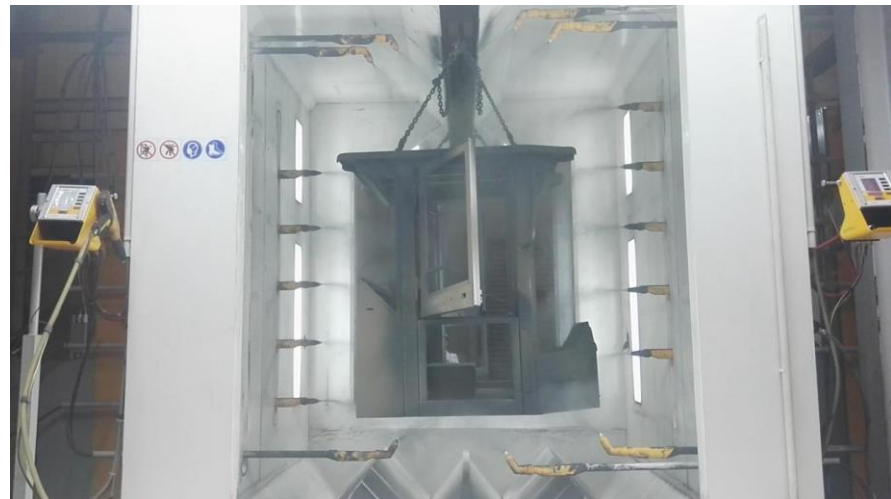

Application Success Stories



Company Profile

Founded in 1993, Lonking Holdings Limited ("Lonking") is one of the largest construction & logistic machinery manufacturers in China. It has 19 wholly owned subsidiaries and four production bases respectively located in Fujian, Shanghai, Jiangxi and He'nan, covering over 3 million square meters. One of them we are discussing today is the hydraulic excavators manufacture in SH. Lonking aims to retrofit its traditional manual coating line to cut down VOC emission continuously developing energy efficient and environmental-friendly products under the banner of governmental tax policies.

Company Expectations

- Quality and production improvement
- VOC Emission reduction
- Cost savings

Key to Gema Success

A Green cost-saving automatic line is well offered for LonKing's expectation.

- LonKing outstands its competitors as CAT/KOMATSO/XCMG by firstly retrofitting its traditional manual line to achieve full automation.
- The automatic Gema line produces perfect coating results especially compared with homemade manual coating on huge and complicated cab door with least manual touch-ups for which only one operator is needed.

- Meanwhile VOC emission reduction in avoidance of governmental tax is effectively realized due to advanced electrostatic powder coating instead of wet paint process.
- The perfect booth ventilation and the closed powder circuit of the OptiCenter prevent powder escape from the system, which significantly reduces waste powder and the contamination of working environment.

Thanks to the good experience with Gema equipment, a new project cooperation with LonKing forklift coating line is coming into place soon!