

Application Success Stories

SCHAKO Group Air conditioning and ventilation

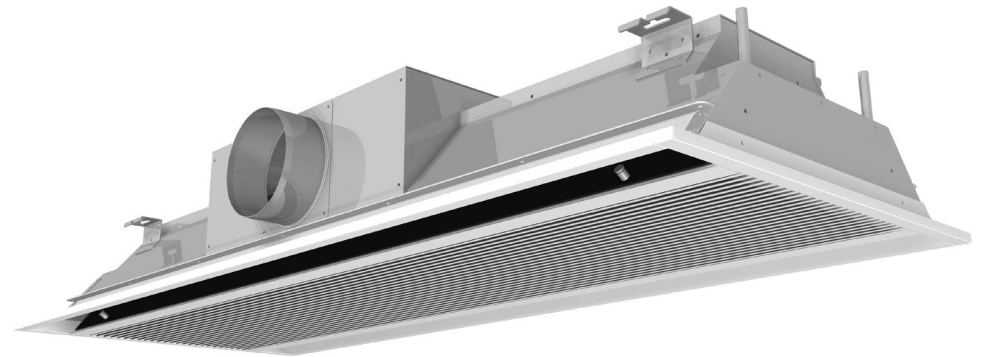

Digitalization

Efficiency

Process reliability

Application Success Stories

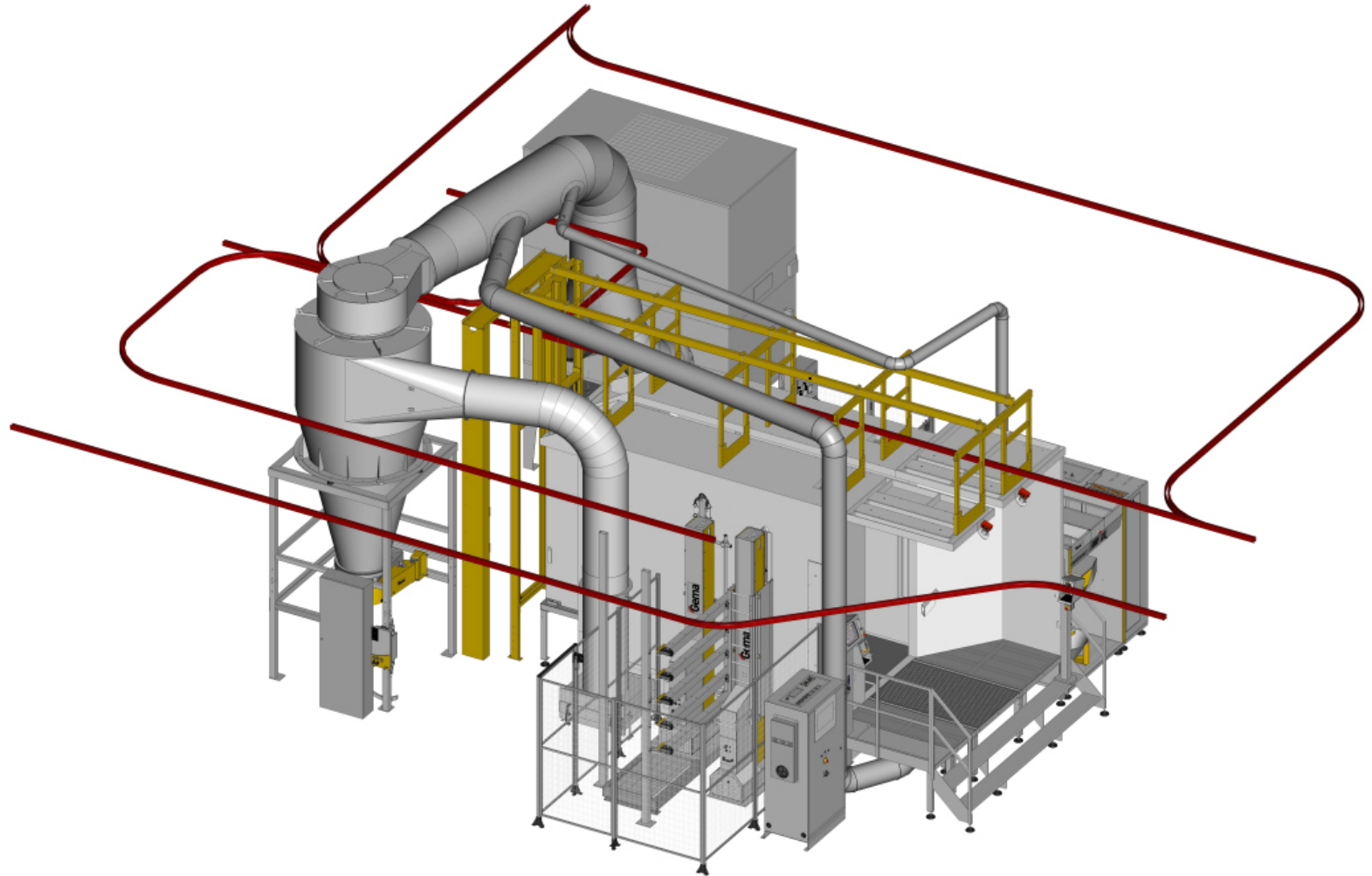

Application Success Stories

Technical Data

Parts:

Cabinets, flat parts, ventilators etc.

Parts size:

H 2'000 mm

W 1'000 mm

L 2'000 mm

Conveyor speed:

Vmax 2,2 m/min

Scope of delivery:

- 1 x MagicCompact EquiFlow BA04
- 1 x OptiFlex AS06-17 P
- 15 x OptiGun GA03-P-1700 automatic gun
- 2 x OptiSelect GM03 manual gun
- 1 x OptiCenter OC03 with 17 x AP01 application pump
- 1 x MagicControl CM30
- 2 x ZA07-18 / XT10-11 reciprocator
- 1 x ZA13-23 reciprocator with 5 x UA04 horizontal axis
- 1x Dynamic Contour Detection



Application Success Stories



SCHAKO produces high quality and innovative components and systems for ventilation and air-conditioning units in five European locations. A substantial proportion of this is developed at the headquarters in Kolbingen (DE) and produced with a high level of vertical integration.

For many years SCHAKO has relied on powder coating solutions by GEMA. Due to the age of the plant, increased quality standards on the market and shorter delivery intervals, a completely new coating line was planned. The aim was to be able to coat the large range of parts in different shapes and sizes with



the greatest possible degree of automation. In order to guarantee process reliability, efficiency and a connection to digitalized order processing, in addition to a high degree of automation, provision was made for the use of modern pump and control technology.

GEMA presented the new dynamic contour recognition with laser scanners and individual infeed axes to representatives from SCHAKO at the specialist trade fair PaintExpo 2018 and in coating trials in St. Gallen. SCHAKO was quickly convinced that it would be better to get the easier to use and more



compact solution than a robot which would require a great deal of programming.

The new powder coating plant process SCHAKO's wide range of parts extremely efficiently and economically. The AP01 application pumps offer maximum process reliability and the dynamic part recognition with individually adjustable guns increases quality, decreases powder consumption and reduces the effort involved in recoating. The latter has been reduced to just one person, who has a very attractive job thanks to local ground suction and touch screens.

Application Success Stories



Application Success Stories

