

# Application Success Stories

**Eldon, one of the major electrical enclosure manufacturers in the world, upgrades its Romanian plant with latest Gema powder coating technology**



Increase production flexibility

Reduce color change time

Increase line automation and coating quality

# Application Success Stories

## Layout

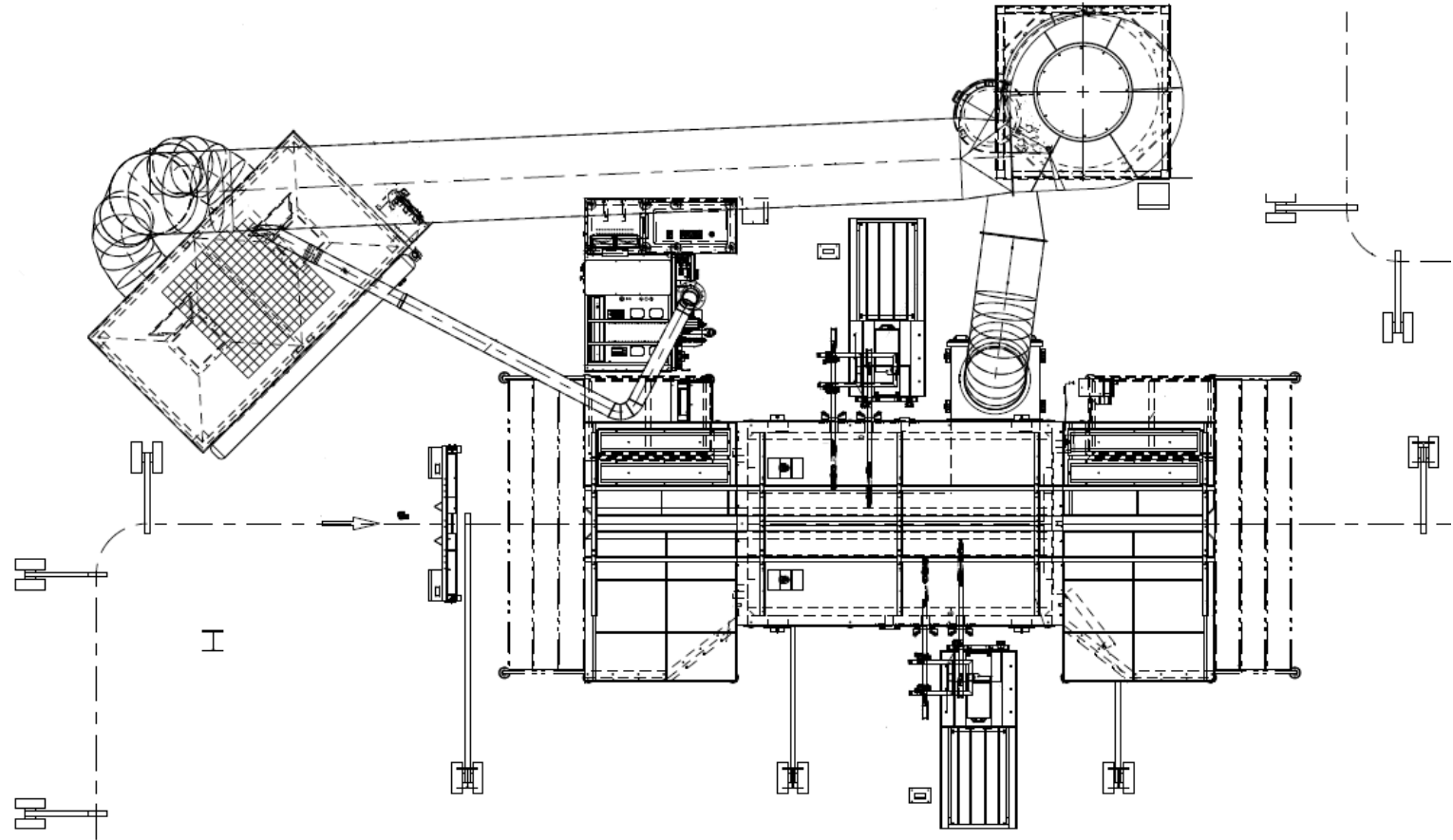

# Application Success Stories

## Installation Key Data

**Parts:** Electrical cabinets

**Parts Sizes:**

H = up to 2'200 mm

W = up to 1'000 mm

L = up to 1'600mm

**Conveyor Speed:**

3,0 m/min

**Scope of supply:**

1x BA04, pre & post touch-up platforms movable

1x OptiCenter OC02, incl. US06

1x OptiFlex AS05-22P / 20x OptiGun GA03-AX, 2x OptiSelect GM03

2x ZA05-23, incl. XT10-10

1x OptiControl CM30

1x Height/width recognition

1x Filter, Cyclone (24'000m<sup>3</sup>/h)



# Application Success Stories



## Company Profile:

Eldon is a global manufacturer of comprehensive standard and customised enclosure solutions for the industrial and building markets. Founded in 1922, Eldon has satisfied customers with its quality, cost efficient enclosure solutions for power & distribution, machines and automation & control applications.



## Company expectations / requirements:

Needs for smaller size production runs and more frequent color changes could not be met by existing Tribo line. Increased market demands required more production capacity and higher line automation, without compromising coating quality standards. New system needed to fit into existing plant layout and be ready for production within 2 weeks.

**Gema Solution:** Modular and flexible line design allowed to integrate new line seamlessly and within the assigned time slot into existing plant. Latest generation automatic powder coating equipment allows for up to 3m/min line speed while maintaining perfect coating quality. Fast color change improved production flexibility to desired levels.