

Application Success Stories



Painters working
conditions improved
喷涂环境的改善

Wet painting to
powder coating
油漆改粉

Complicated part
工件复杂

Application Success Stories

Layout

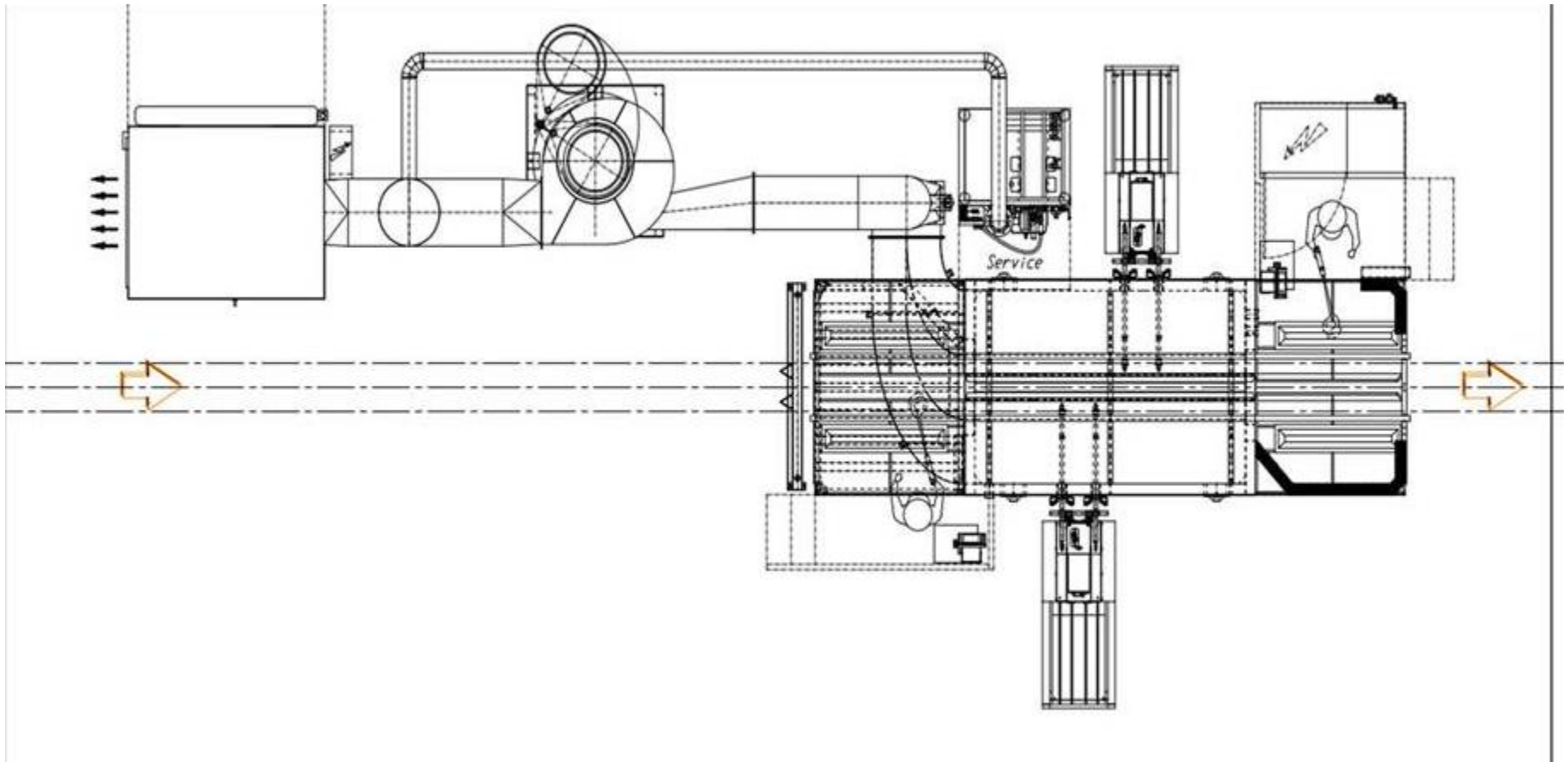

Application Success Stories

Installation Key Data

Parts:	Truck Part
Parts Size:	H 1'750 mm
	W 450 mm
Line Speed:	up to 3 m/min
Description:	
	1 x Magic Compact / 16,000 m ³ / h
	1 x OptiFlex AS05- 12+2
	12 x OptiGun GA02
	2 x OptiSelect GM03
	1 x MagicControl CM-30
	1 X Opti Center OC02

Installation: 2014



Application Success Stories



◆ Before customer use wet painting, it's first time to coat truck part by powder.

◆ After few months production, following data collected from customer:

◆ Environment improved

	Investment (thousand Yuan)		Material cost (RMB ¥ / per truck)		Energy Consumption (per truck)	Construction period
	Equipment	Construction & waste gas treatment	powder	diluent, Coagulant for paint fog		
liquid	500	200	~ ¥ 150 / truck	~ ¥ 40 / truck	38.83 / truck	6 months
powder	207	0	~ ¥ 120 / truck	~ ¥ 0 / truck	18 / truck	3 months