

Application Success Stories



Swallow Architectural Coatings Ltd invest in the latest powder coating technology from Gema Europe, boosting productivity and enhancing their service offering!

Fast colour change

Improved powder yield

Repeatable and consistent results

Application Success Stories

Layout

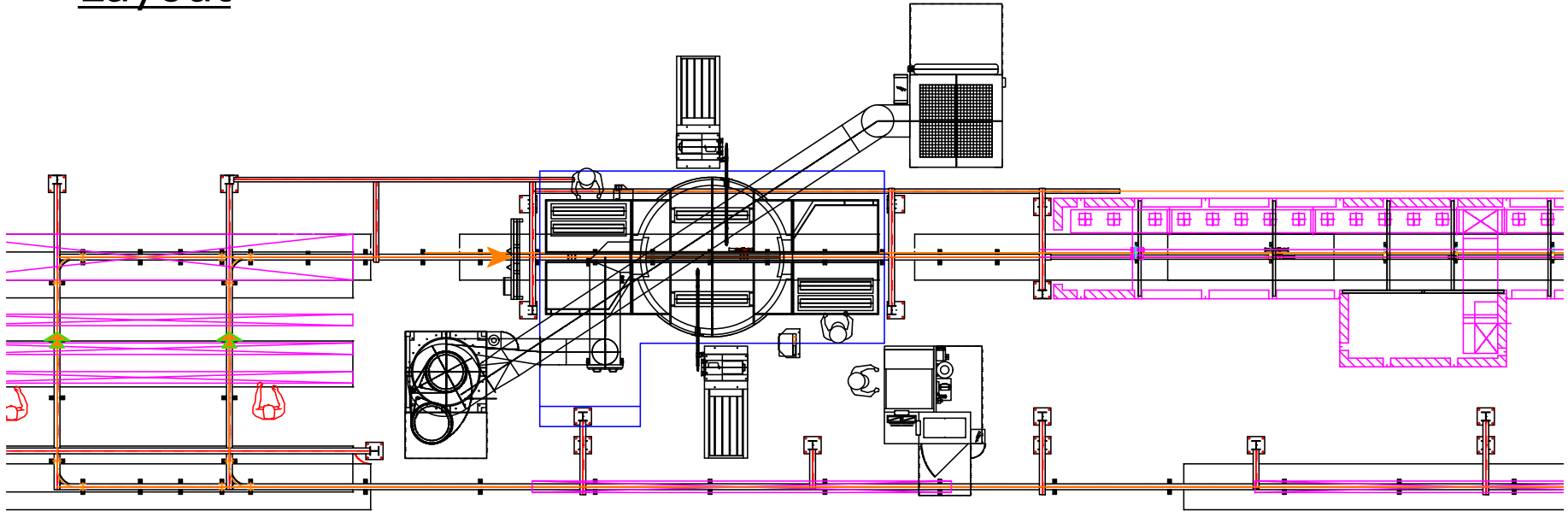

Company Profile: Operating from a purpose built facility in Elland, West Yorkshire, Swallow Architectural Coatings offers a complete polyester powder coating service providing exceptional high quality paint finishes to architectural aluminium extrusions, aluminium panels, aluminium cladding, curtain wall systems, sliding and bi-fold door systems.

Application Success Stories

Installation Key Data

Parts:

Aluminum Profiles

Production data:

- 1700mm high
- 600mm wide
- 1.5m per min

System Type:

- MagicCylinder QCS04
- 6 Automatic guns
- 1 manual station
- OptiCenter OC03
- 7 AP01 Pumps
- CM30 control system
- Product recognition
- X & Z reciprocation



Application Success Stories



Production line overview:

Managing director, Andrew Swallow explained "We have made significant investments within our business over the past 18 months, this includes a brand new purpose build 28,000



sq.ft factory, equipped with a 7 stage chrome free pre-treatment system, MagicCylinder 4 fast colour change booth equipped with the latest dense phase application guns, as well as a high efficiency oven.



The system incorporates a power and free track provides total flexibility in terms of our production process and allows us to batch work, this investment has taken our business onto the next level in terms of quality and service provision."

Application Success Stories

Key objectives and success areas:

- ✓ Double the coating capacity and capability to meet increasing demand
- ✓ Reducing the product turnaround time to support customer requirements
- ✓ Improve efficiencies in terms of processes, materials, and environmental aspects
- ✓ Significant increase in automation and process control
- ✓ Enhanced product finish with 100% capacity increase
- ✓ 90% reduction in powder waste thanks to the high efficiency powder recovery

When considering the type of investment and the decision process Andrew explained, "We had several specific needs and requirements from the new powder coating system, this included increasing the process speed, improving our green credentials through powder recovery, automating the process and enhancing the working environment. As the process was mass transformation for our business it was also key to identify suppliers who offer high levels of after-sales support to ensure we get the best from our investment moving forward."

Andrew continued "During the evaluation process Gema benchmarked our existing facility, this involved a comprehensive plant audit, from this several stages of investment were identified. Investments ranged from a simple upgrade of the existing powder application guns, through to the complete replacement of the complete booth with the latest generation fast colour change system. Upon evaluation it became clear that in order to position our business to win we needed to invest in a complete line, and capture all of the benefits available."

Application Success Stories

Investing wisely, in the right equipment has paid dividends

When asked about the main benefits of the system Andrew went on to explain "The Gema system allows us to carry out contamination free colour changes quickly and easily, for some colours the change over time is below 5 minutes, when you combine this with the high efficiency recovery performance, and comprehensive system automation we now operate extremely efficiently.

The control system is extremely easy you use, its intuitive and promotes the operators to get the best from the facility. Moving away from venturi powder pumps to Gema's SIT dense phase technology has paid dividends, we now have complete control of the process repeatability and can call up pre-set programs directly on the touch screen, and quickly make adjustments depending upon specific requirements."

Leon Hogg, Business Unit Manager - Gema UK explained, "During our first meeting Andrew was clear about the vision for Swallow's business and set out their future, this vision centered around Swallows unwavering commitment to their customer

base, one that focuses on delivering premium quality coatings quickly and competitively, without compromise.

It has been fantastic to be part of this journey, and witness first hand Andrew's visions transform into reality. We look forward to working with Andrew and the team at Swallow, supporting him in the future as the business experiences its next phase of growth."

